

Décanteur Primaire
Stockage des boues
Tampon

SBR

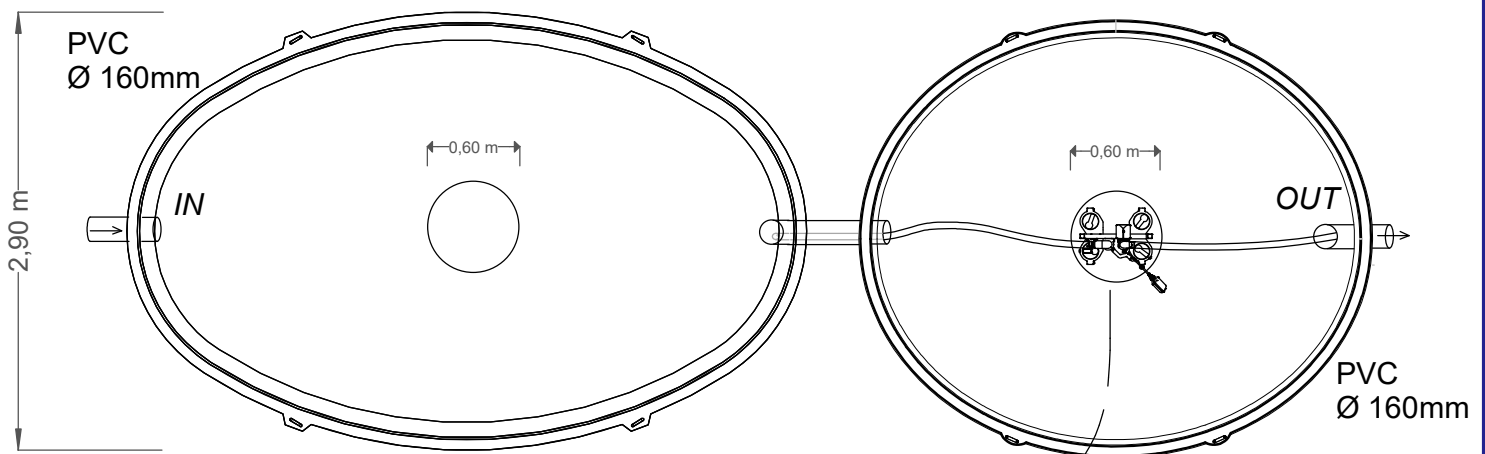
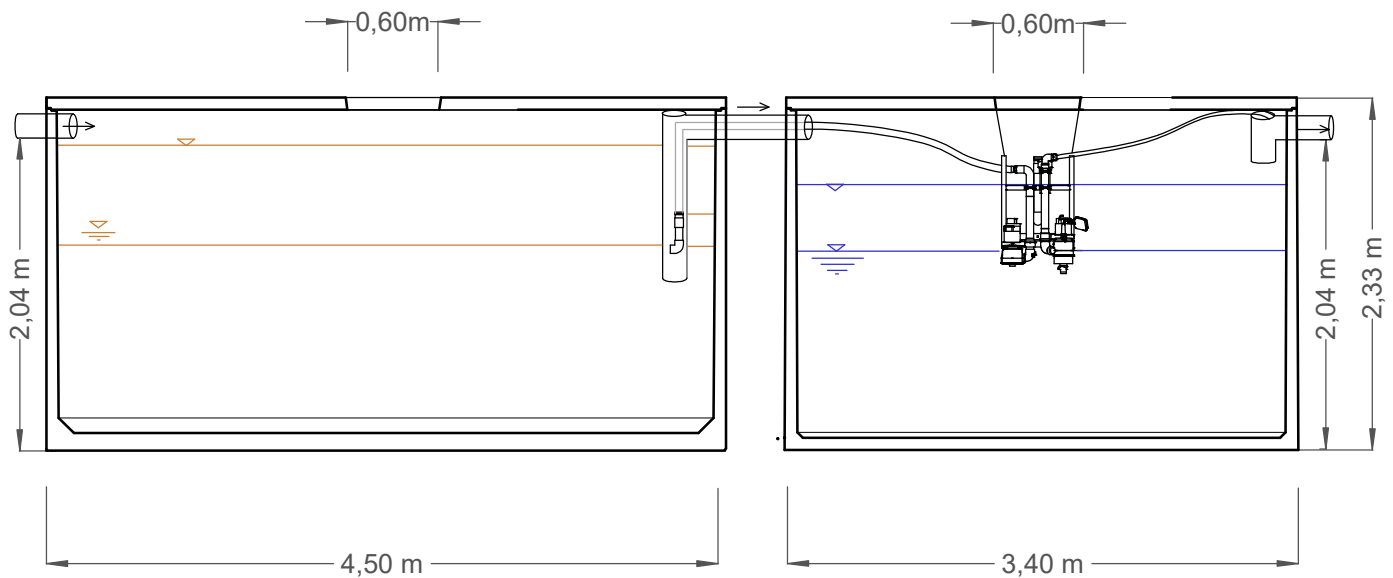

gaine Ø63 mm min.
avec tire fil

Capacité max : 50 EH
Poids décanteur : 8 980kg
Poids SBR : 6 850 kg
Matériau: Béton
Conso elect.: 1392 kWh/an
Charge hydraul.max : 7,50 m3/jour



EN 12 566-3

ATB Belgique SRL

Tel : 087 37 62 71
info.belgique@atbwater.com
www.micro-station-atb.be