

Décanteur Primaire  
Stockage des boues  
Tampon

SBR

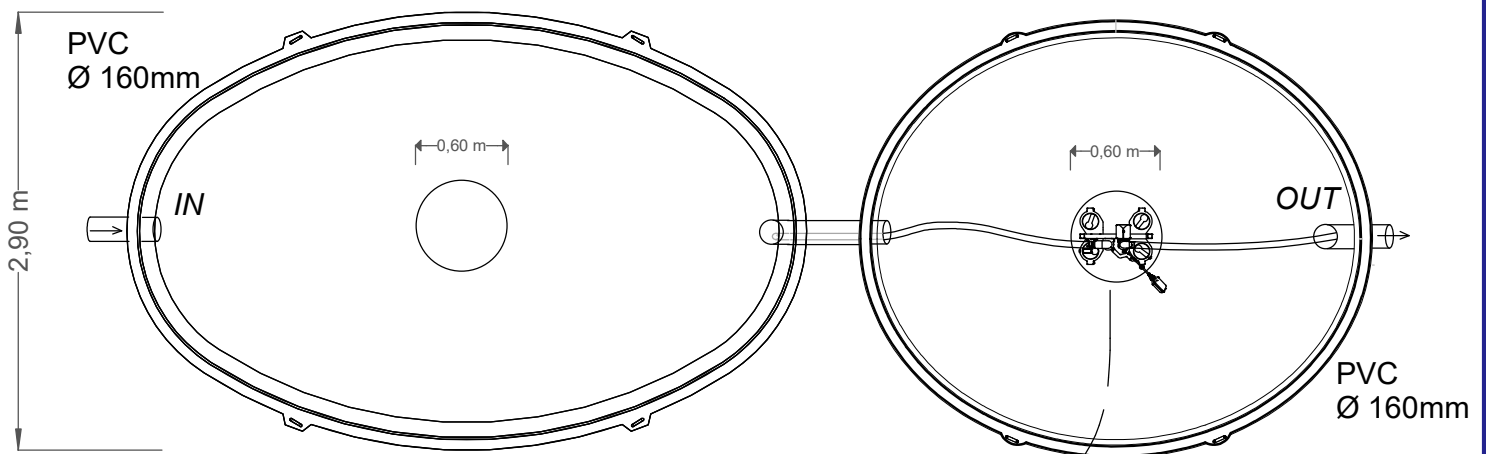
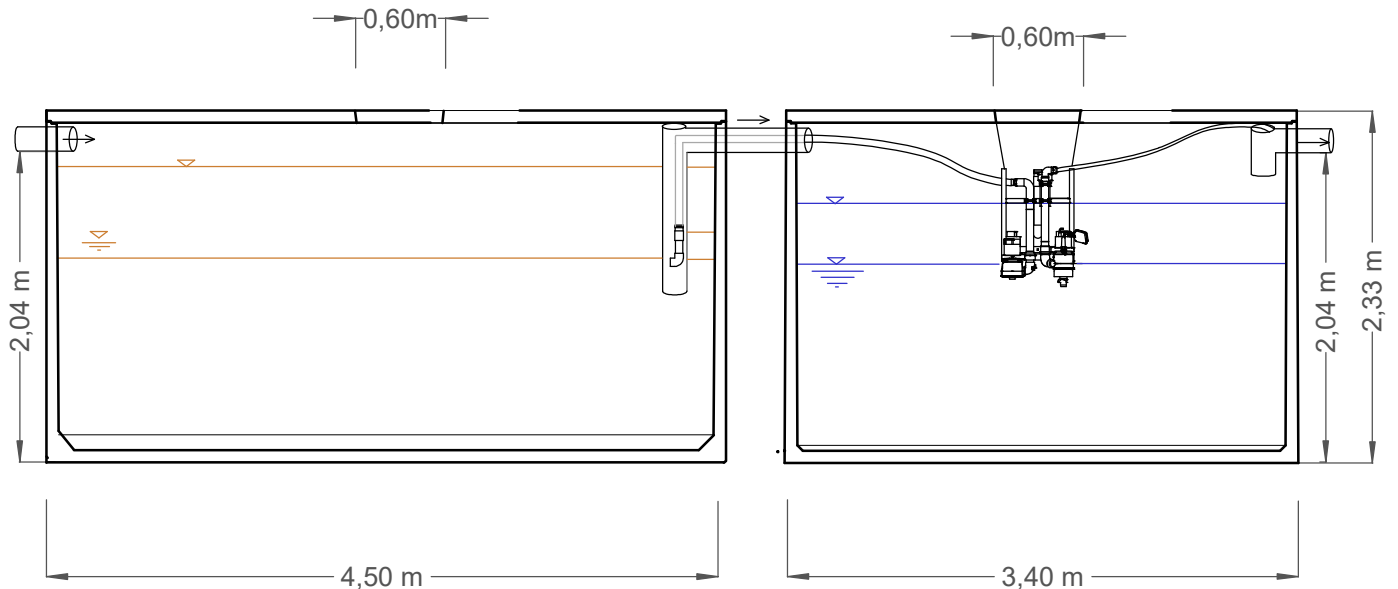

gaine Ø63 mm min.  
avec tire fil

Capacité max : 45 EH  
Poids décanteur : 8 980kg  
Poids SBR : 6 850 kg  
Matériau: Béton  
Conso elect.: 1253 kWh/an  
Charge hydraul.max : 6,75 m3/jour



EN 12 566-3

**ATB Belgique SRL**

Tel : 087 37 62 71  
info.belgique@atbwater.com  
www.micro-station-atb.be