

AQUAmax[®] Basic - 16 EH

Type P - Renforcé

2020/06/021/A

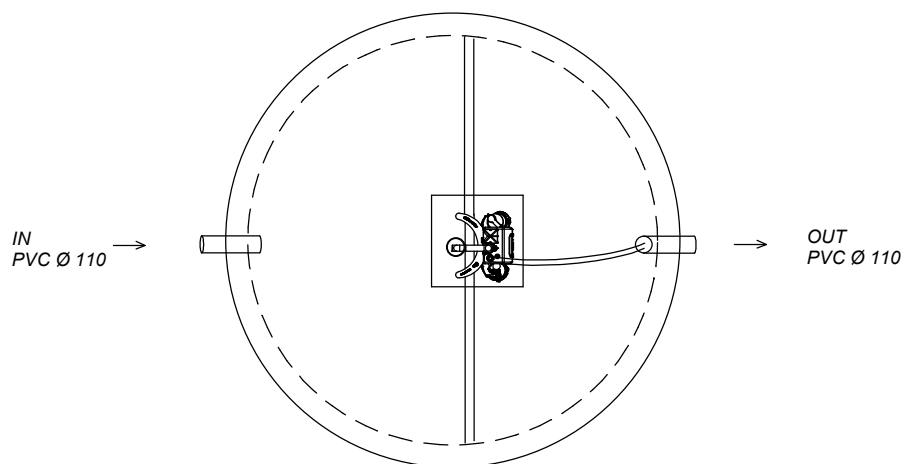
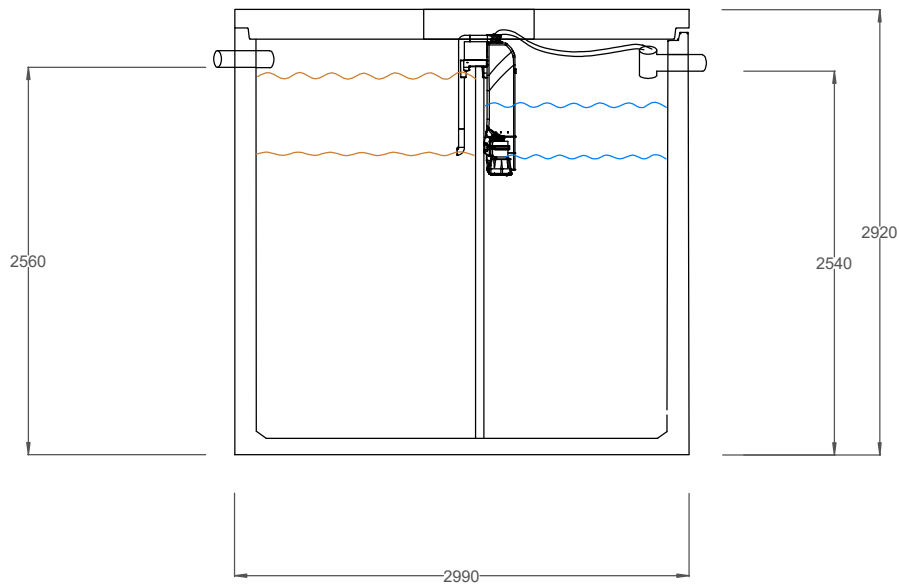

Capacité max : 16 EH
Poids cuve : 12 550kg
Matériau: Béton
Conso elect.: 495 kWh/an
Charge hydraul.max : 2,40 m3/jour



EN 12 566-3

ATB Belgique SPRL

Tel/Fax : 087 37 62 71
info@atb-belgique.be
www.micro-station-atb.be