

Décanteur primaire
Stockage des boues
Tampon

SBR

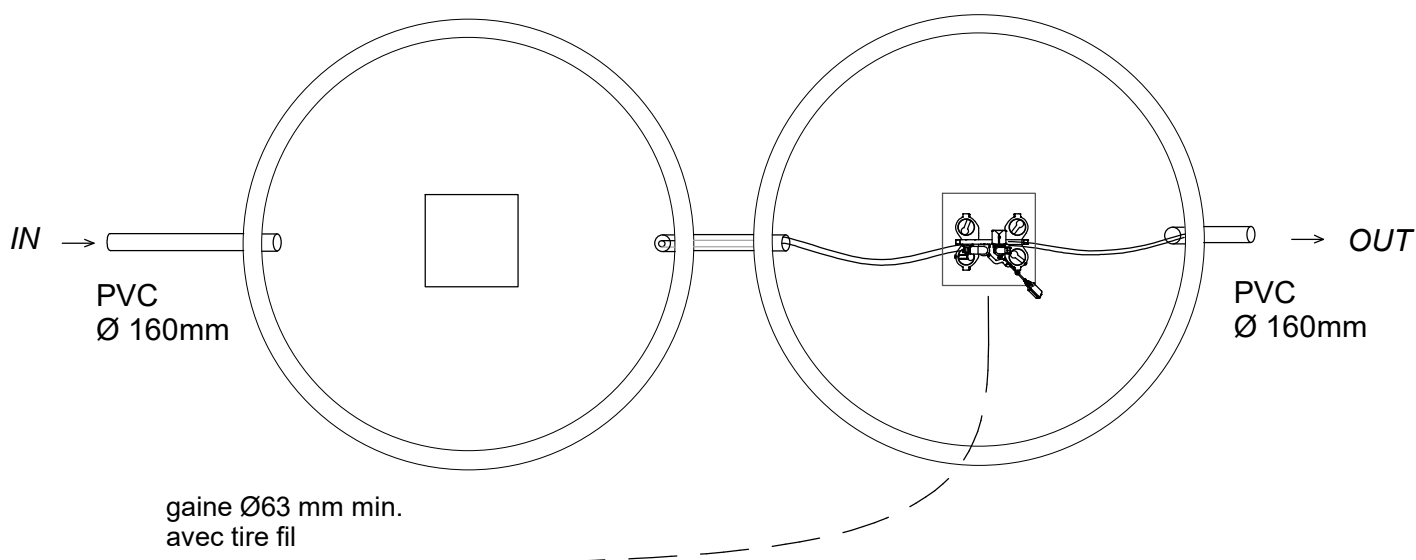

Capacité max : 45 EH
 Poids décanteur : 11 900 kg
 Poids SBR : 11 900 kg
 Matériau: Béton
 Conso elect.: 1253 kWh/an
 Charge hydraul.max : 6,75 m³/jour

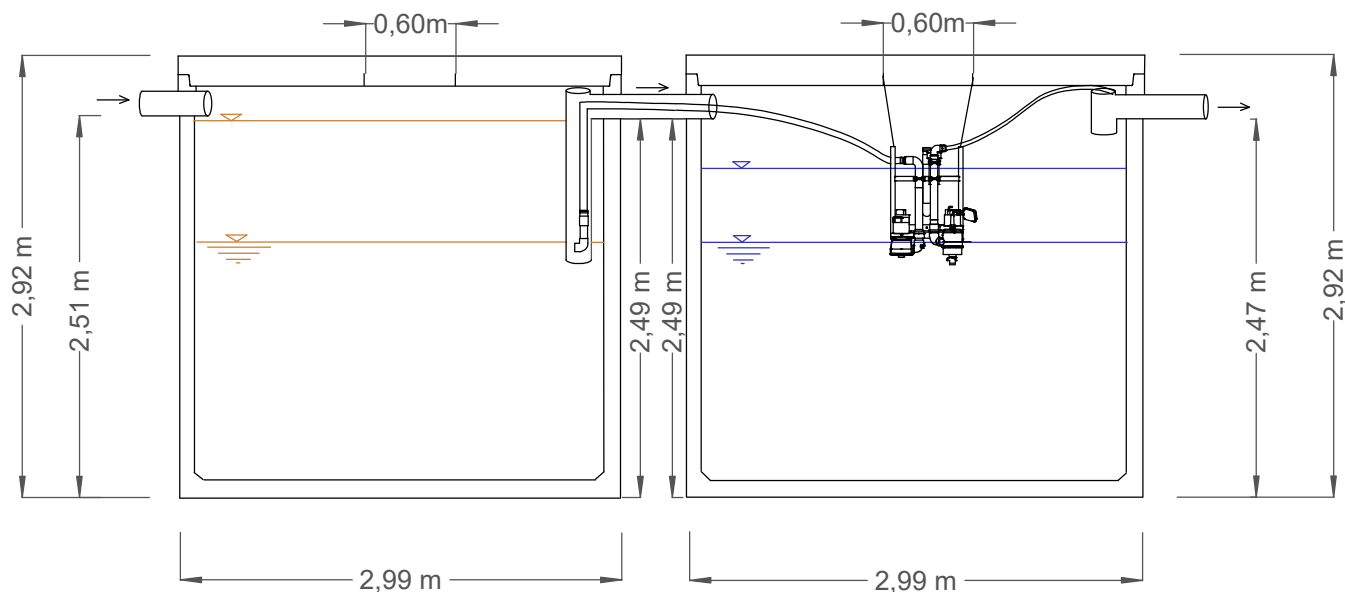

EN 12 566-3

ATB Belgique SPRL

Tel/Fax : 087 37 62 71
 info@atb-belgique.be
 www.micro-station-atb.be