

Décanteur Primaire
Stockage des boues
Tampon

SBR

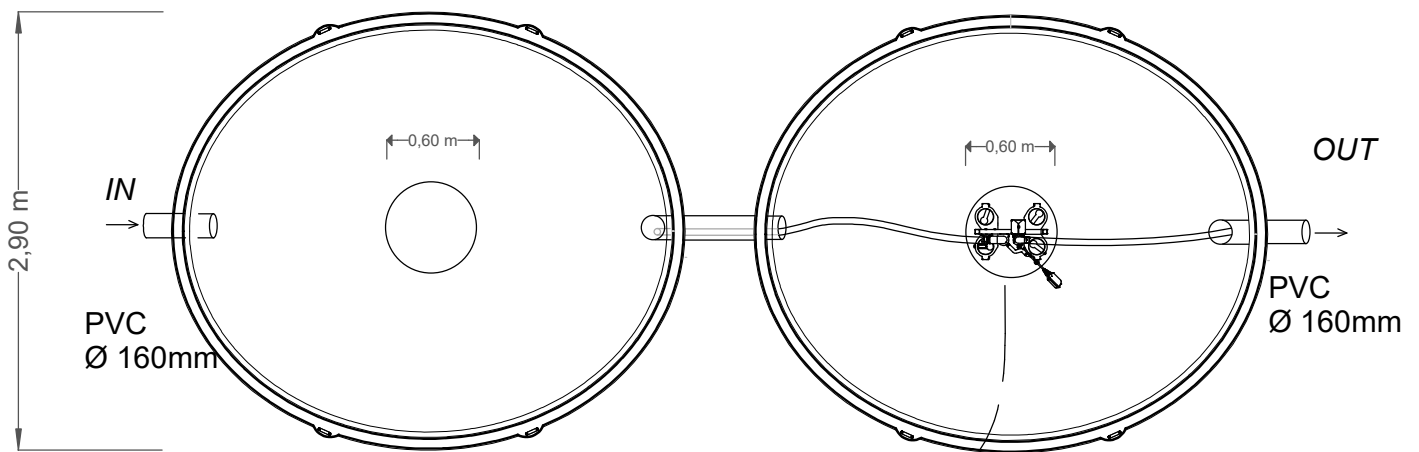
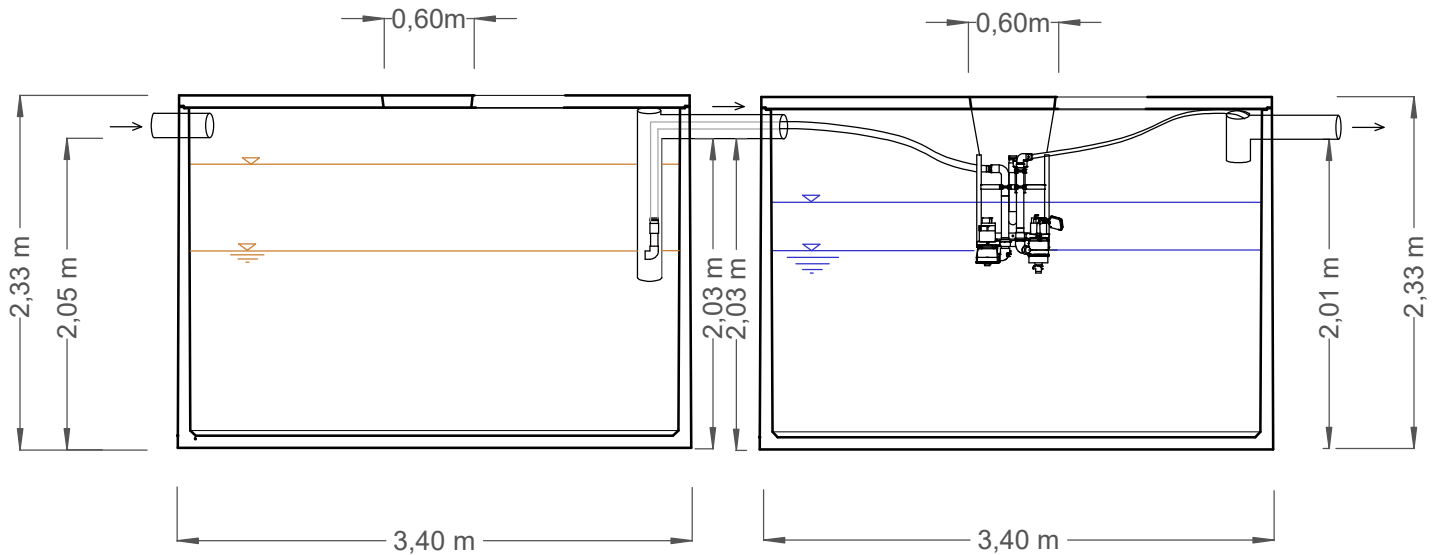

gaine Ø63 mm min.
avec tire fil

Capacité max : 35 EH
Poids décanteur : 6 850 kg
Poids SBR : 6 850 kg
Matériau: Béton
Conso elect.: 974 kWh/an
Charge hydraul.max : 5,25 m3/jour



EN 12 566-3

ATB Belgique SPRL

Tel/Fax : 087 37 62 71
info@atb-belgique.be
www.micro-station-atb.be