

Décanteur primaire  
Stockage des boues  
Tampon

SBR

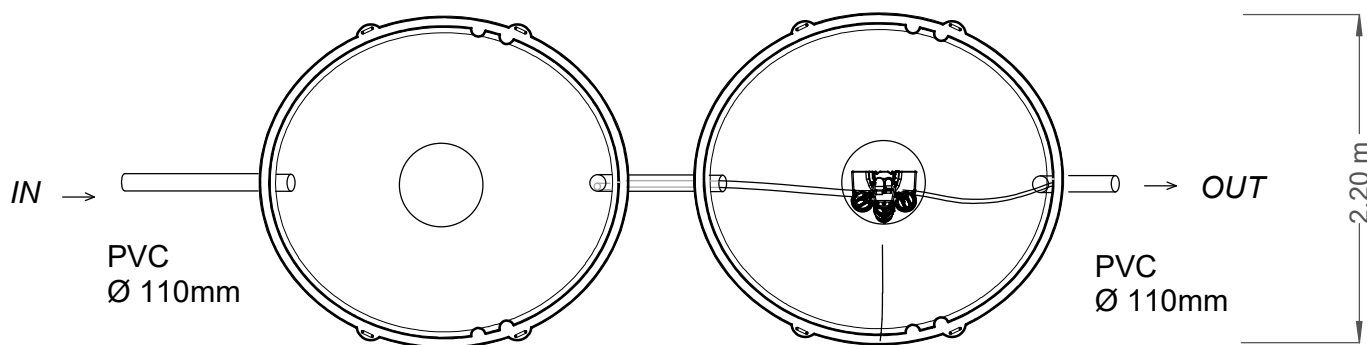
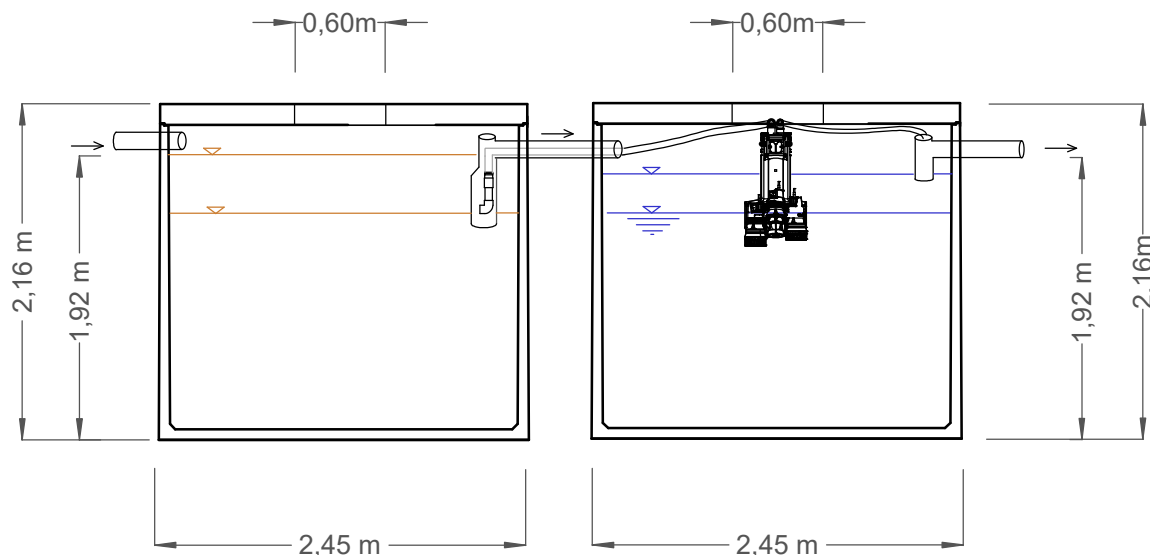

gaine Ø63 mm min.  
avec tire fil

Capacité max : 13 EH  
Poids décanteur : 4 550 kg  
Poids SBR : 4 550 kg  
Matériau: Béton  
Conso elect.: 423 kWh/an  
Charge hydraul.max : 1,95 m<sup>3</sup>/jour



EN 12 566-3

**ATB Belgique SPRL**

Tel/Fax : 087 37 62 71  
info@atb-belgique.be  
www.micro-station-atb.be