

# AQUAmax<sup>®</sup> Basic - 16 EH Type P

N° 2015/06/125/A

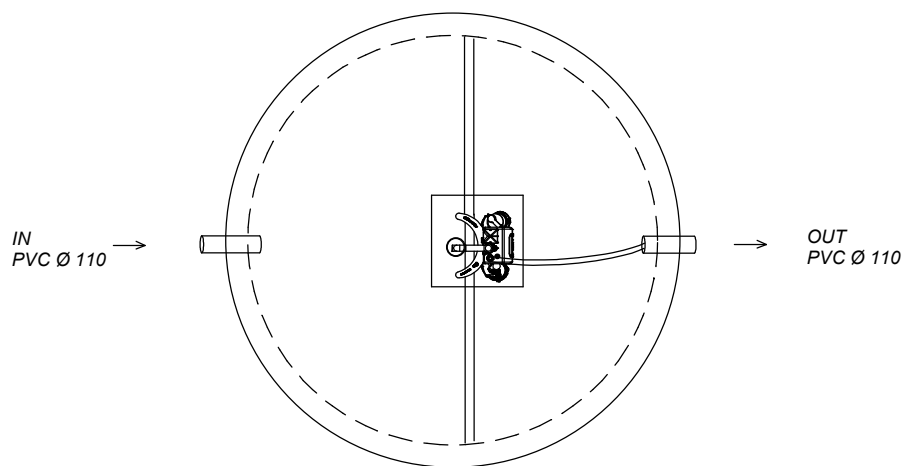

Capacité max : 16 EH  
Poids cuve : 10 500kg  
Matériau: Béton  
Conso elect.: 678 kWh/an  
Charge hydraul.max : 2,40 m3/jour

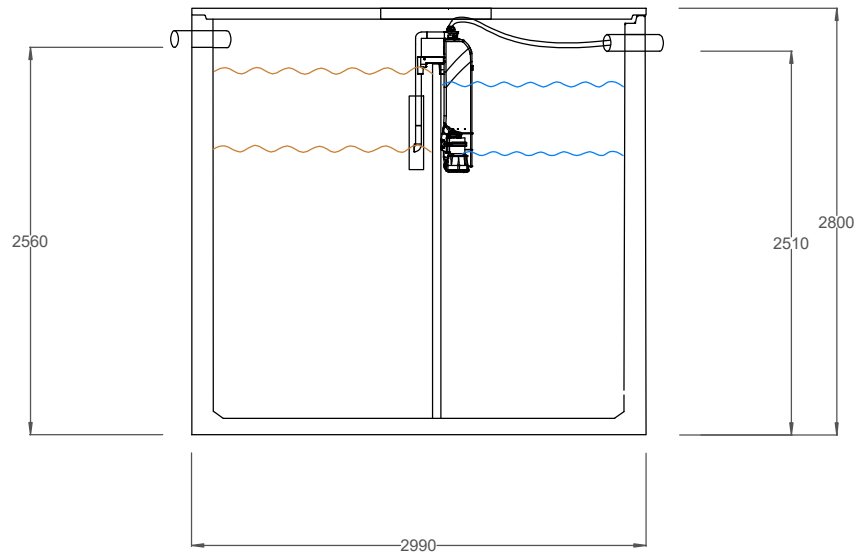

EN 12 566-3

**ATB Belgique SPRL**

Tel/Fax : 087 37 62 71  
info@atb-belgique.be  
www.micro-station-atb.be